

GHG EMISSIONS OF INNOVATIVE TECHNOLOGIES PROVIDING BIOMETHANE AND VALUE-ADDED PRODUCTS FROM CO₂

Katja Oehmichen¹, Stefan Majer¹, Jaqueline Daniel-Gromke

¹ DBFZ, Dept. Bioenergy Systems, Leipzig; ² DBFZ, Dept. Biochemical Conversion, Leipzig

INTRODUCTION

In SEMPRES-BIO project three case studies demonstrate innovative biomethane production technologies with biogenic CO₂ valorisation at different process stages: Case study 1 (CS 1) combines proton exchange membrane water electrolysis (PEM) and CO₂ bio-methanation at a wastewater treatment plant. Case study 2 (CS 2) combines a thermochemical pyrolysis process and bio-methanation. Case study 3 (CS 3) involves the production of bio-LNG and liquefied CO₂ (LCO₂) by a cryogenic process. The three pathways have been assessed using two complementary approaches: (a) an ISO 14040/44-based LCA focusing on core process performance, and (b) an evaluation under the EU Renewable Energy Directive (EU RED) framework covering the entire value chain.

CONCEPTS

CS 1 Biogas & Methanation

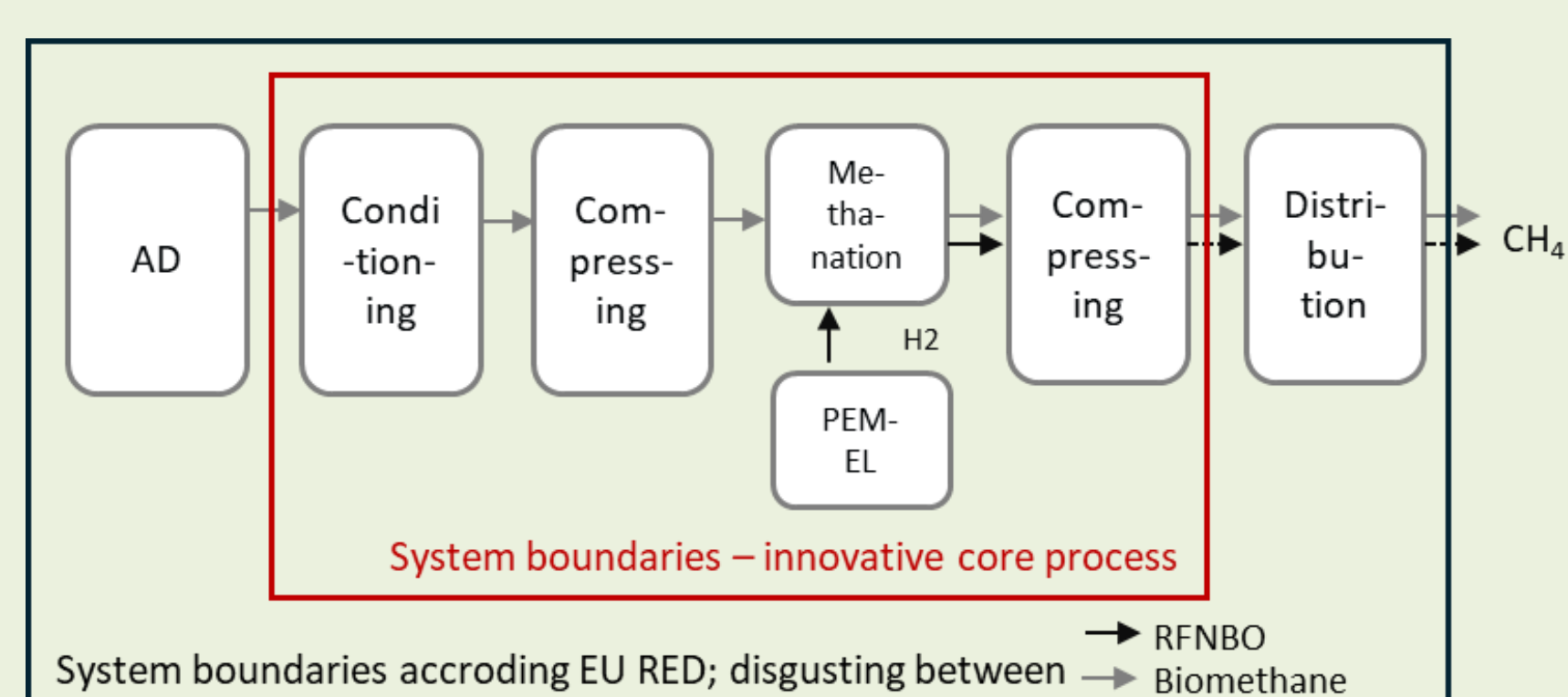

System boundaries vary by method (LCA vs. EU RED) >> final methane combines biogas CH₄ (biomethane) and H₂-based conversion of biog. CO₂ (RFNBO)

ASSUMPTIONS

- Electricity from Spanish grid (202 gCO₂eq/kWh) assumed for all processes.
- Exception: PEM electrolysis uses renewable electricity from solar-power
- Analysis LCA >> two scenarios under consideration: w/o and w/ gas recycle to use unreacted hydrogen
- Analysis according EU RED >> distinction between biomethane and RFNBO

RESULTS

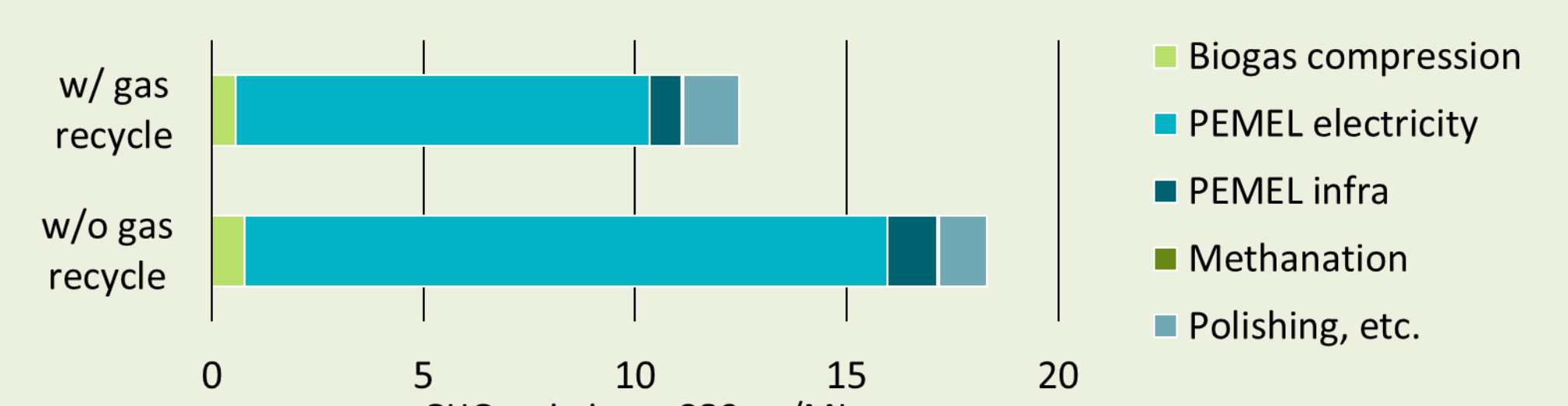

Specific GHG emissions from the innovative core process under consideration of two scenarios

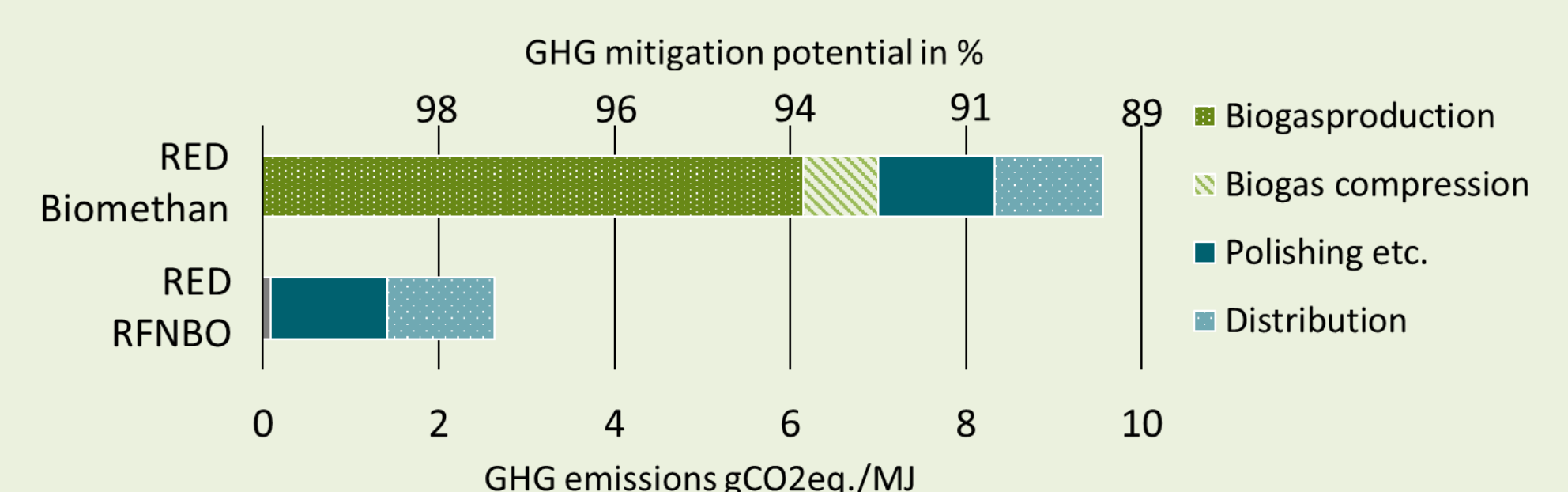

GHG emissions and mitigation potential according EU RED distinguished between RFNBO and Biomethane

CS 2 – Pyrolysis & Upgrading

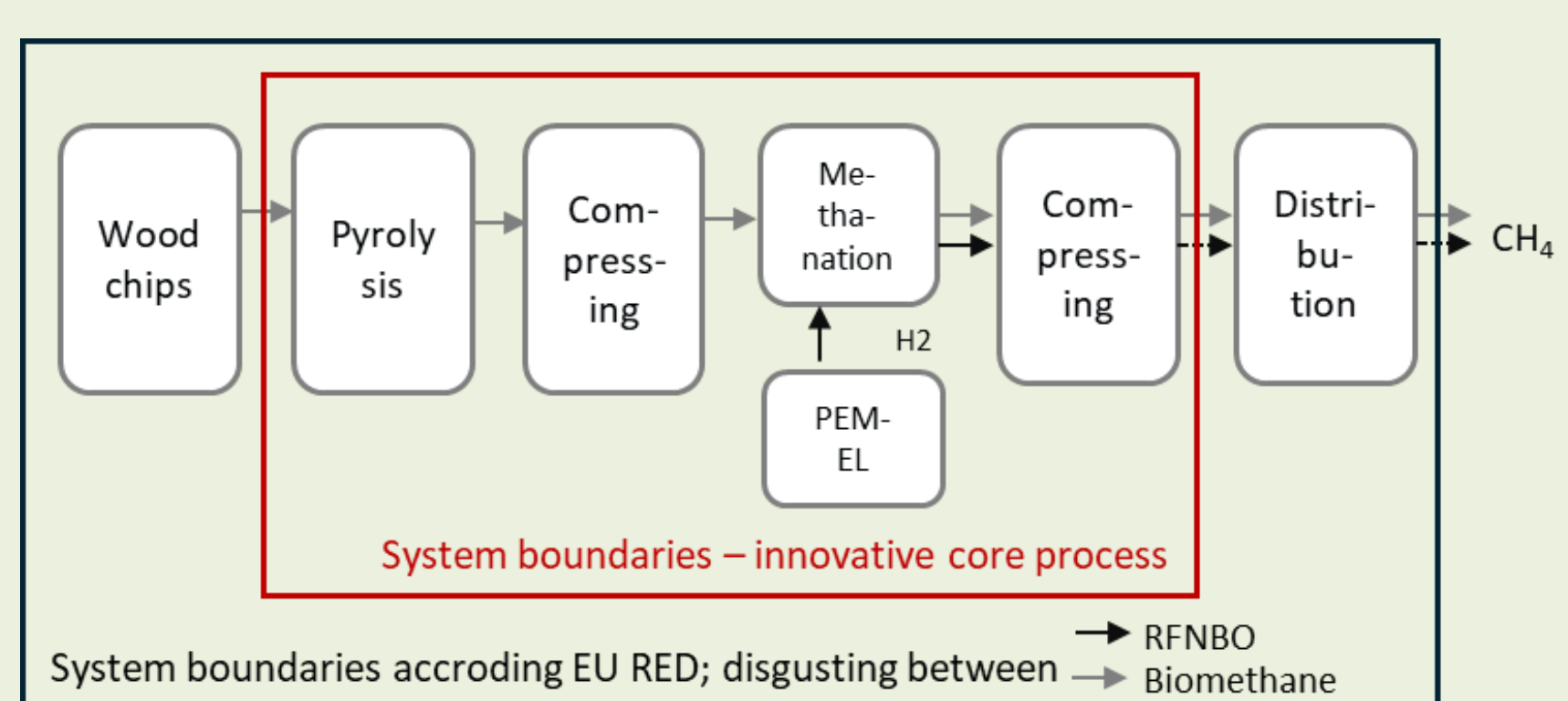
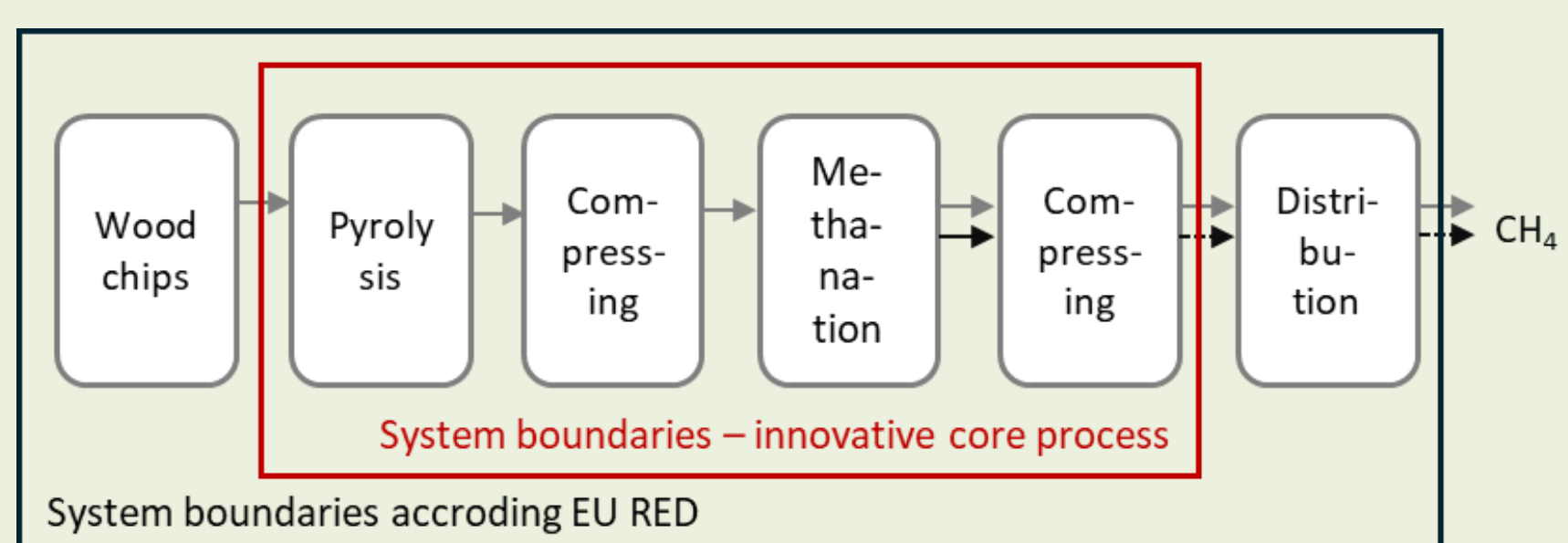

- Electricity: French grid (77gCO₂eq/kWh)
- Exception: PEMEL uses renewable electricity from wind
- Biochar: C-content 77% (89% permanent carbon according IPCC)
- Analysis LCA >> two scenarios under consideration: w/o and w/ H₂ addition
- Analysis according EU RED for scenario w/ H₂ addition >> distinction between biomethane and RFNBO

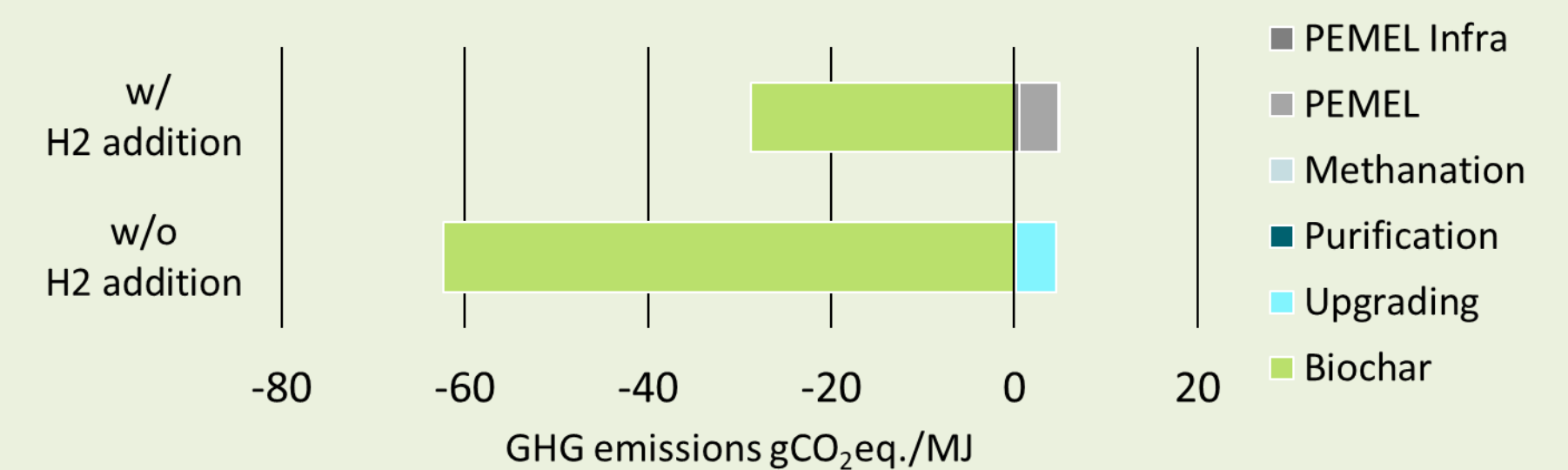

Specific GHG emissions from the innovative core process under consideration of two scenarios

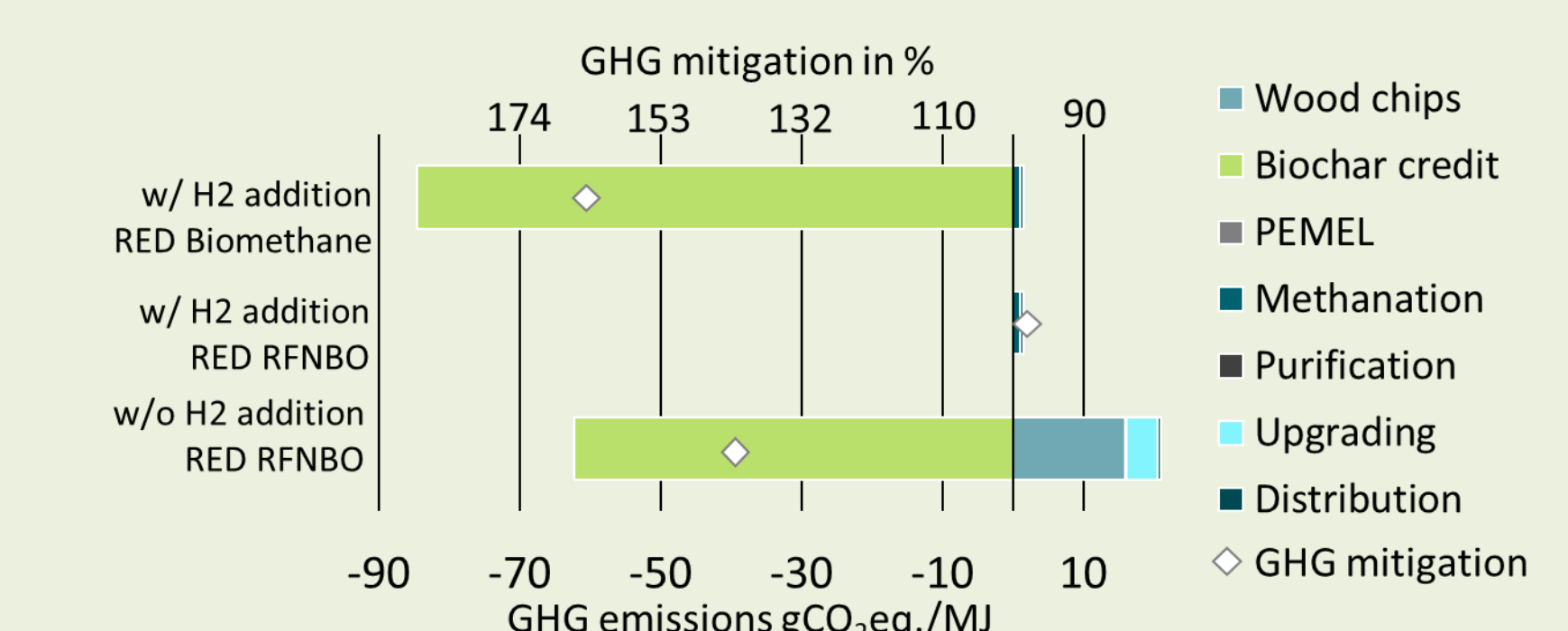

GHG emissions and mitigation potential according EU RED distinguished between RFNBO and Biomethane for scenario with H2 addition

CS 3 – Biogas & Cryogenic process

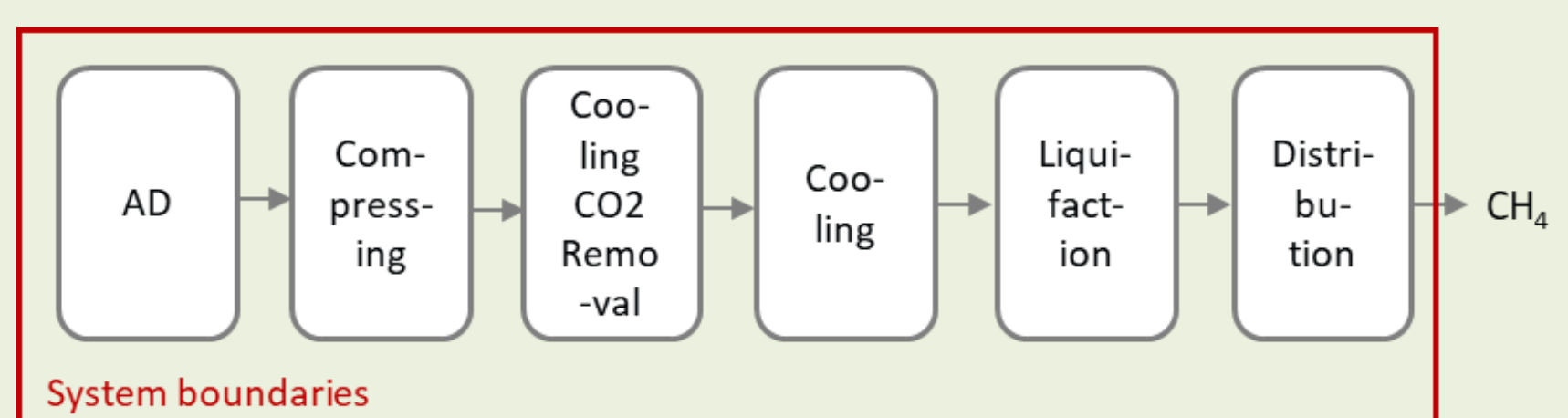

- Electricity: Belgish grid (204 gCO₂eq/kWh)
- Credits for improved manure management
- Credits – industrial use of CO₂

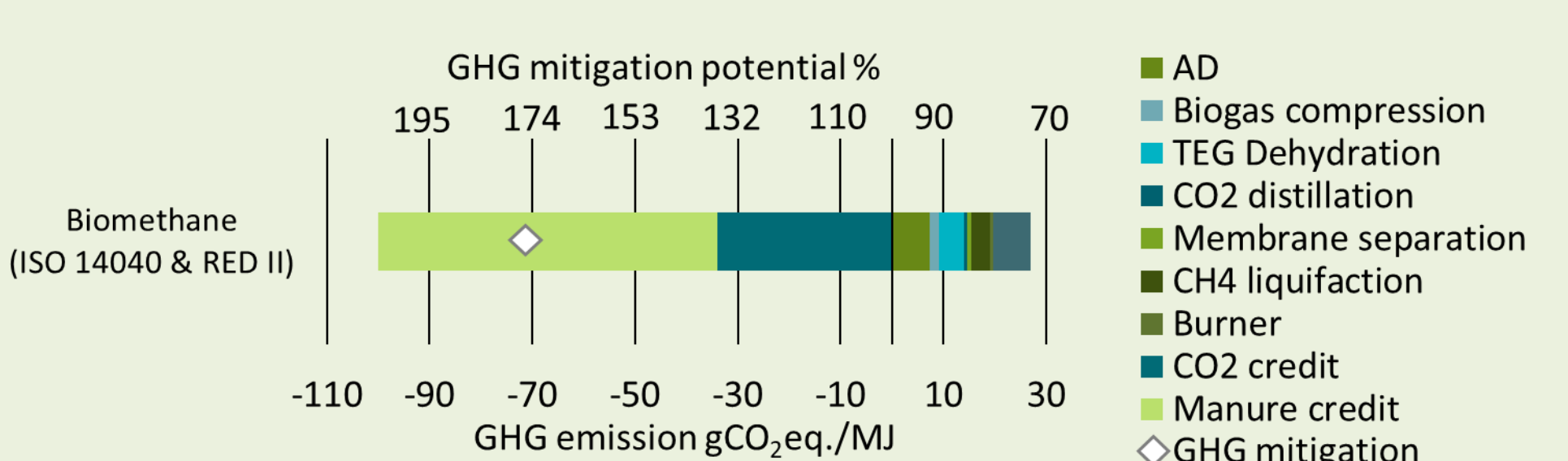

GHG emissions and mitigation potential

CONCLUSION

Overall, all case studies show substantial potential for reducing GHG emissions in renewable methane production. At the same time, the comparison of ISO-based LCA and EU RED methodologies reveals significant differences in results, underlining the need for transparent assumptions and consistent methodological frameworks when evaluating innovative bioenergy systems.